

High Precision Digital Rain Gauge with Indoor Temperature and Humidity



Contents

1. Introduction.....	2
2. Get Started.....	2
2.1 Parts List.....	2
2.2 Recommend Tools	3
2.3 Installation.....	3
2.4 Mount outdoor sensor.....	7
3. Console Operation	10
3.1 Normal Mode	11
3.2 SET Mode	12
3.3 Rain History Mode	13
3.4 MIN/MAX Mode.....	14
3.5 HI/LO Alarm Set Mode.....	14
3.6 Factory Reset/Clear Memory.....	15
4. Function.....	16
5. Maintenance.....	17
6. Troubleshooting Guide.....	18
7. Specifications	21
8. Liability Disclaimer	22
9. FCC Statement.....	22
10. Warranty Information.....	25

1. Introduction

Thanks for your purchasing of the WH5360B High Precision Digital Rain Gauge with Indoor temperature and humidity. To ensure the best product performance, please read this manual and retain it for future reference.

2. Get Started

Note:

Before placing and installing all components of the rain gauge at their final destination, please set up the rain gauge with all parts being nearby for testing the correct function.

Power up sequence must be performed in the order shown in this section (insert batteries in the Display Console first, Remote Sensor second).

Attention:

- Do not mix old and new batteries
- Do not mix Alkaline, Standard, Lithium or Rechargeable batteries
- Ensure batteries are installed correctly with regard to polarity +/-

2.1 Parts List

One Display Console (Receiver)

One Rain Collector (Transmitter)
One User Manual

2.2 Recommend Tools

Hammer for installing remote transmitter(rain collector).

2.3 Installation

Wireless Rain Collector Set Up

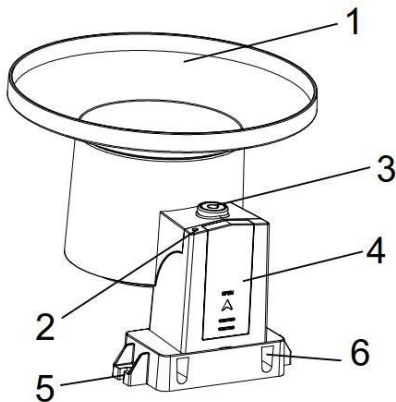

1. Rain collector
2. LED Indicator
3. Bubble level
4. Battery door
5. Screw hole
6. U-bolt install hole

1. Install batteries

Insert 1XAA batteries in the battery compartment. The LED indicator will turn on for four seconds and normally flash once every 49 seconds (the sensor transmission update period).

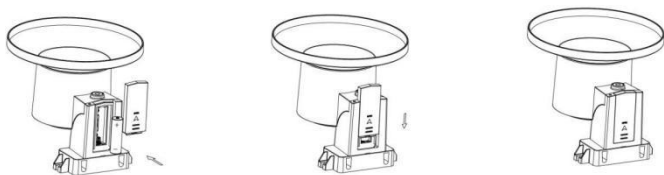

Note: If no LED light up or is lighted permanently, make sure the battery is inserted the correct way or a proper reset is happened. Do not install the batteries backwards. You can permanently damage the outdoor sensor

Note: We recommend lithium batteries for cold weather climates, but alkaline batteries are sufficient for most climates. We do not recommend rechargeable batteries. They have lower voltages, do not operate well at wide temperature ranges, and do not last as long, resulting in poorer reception.

Initial Display Console Set Up

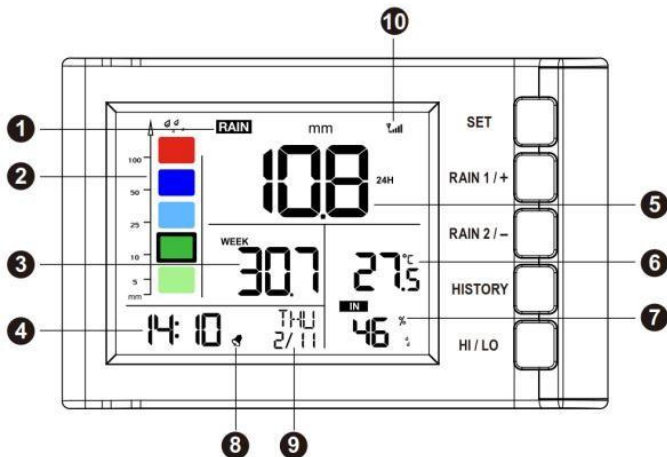

1. Rainfall data display
2. Rainfall grade graph
3. Rainfall of day/week/month/year display
4. Time
5. Rain rate/event/1h/24h display
6. Indoor temperature
7. Indoor humidity
8. Alarm icon
9. Date/Week
10. Signal icon

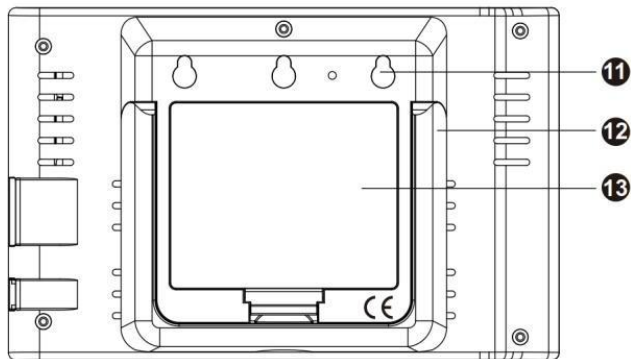

11. Wall-mounted hole

12. Table stand

13. Battery door

2. Install the batteries. The unit will turn on all segments of the LCD for 3 seconds after power on and display setting value. Then the unit will start to register the outdoor channel which takes 3 minutes.

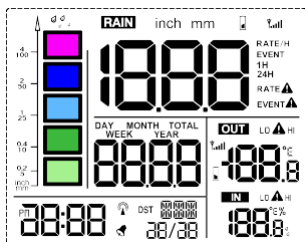

Full display

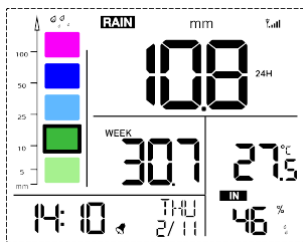

Normal display

2.4 Mount outdoor sensor

Mount with U-bolts

The mounting assembly includes two U-Bolts and a bracket that tightens around a 1" to 2" diameter pole (included a D32*H200mm stainless steel tube) using the four U-Bolt nuts.

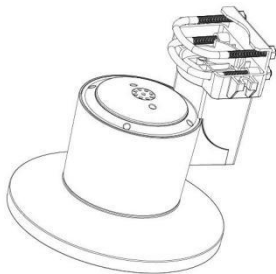
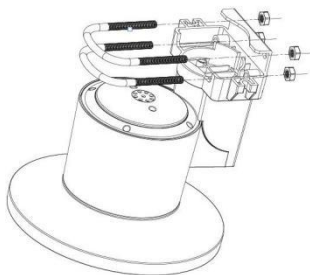

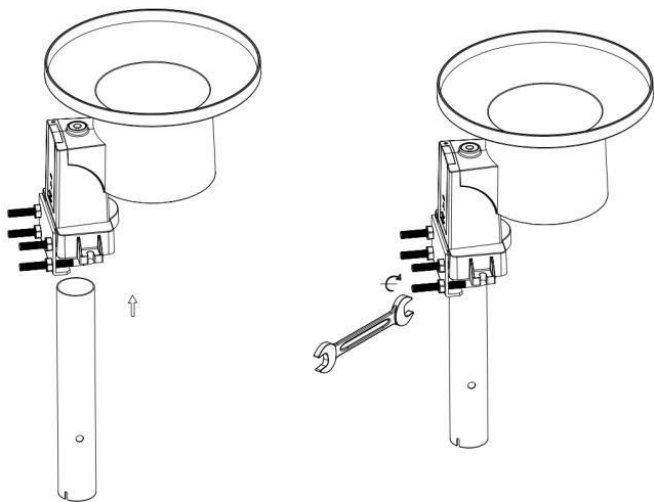

Note: Use the bubble level beside the rain sensor as a guide to verify that the sensor is leveled.

Mount with screws

The mounting assembly also includes two screws for installation on a flat place.

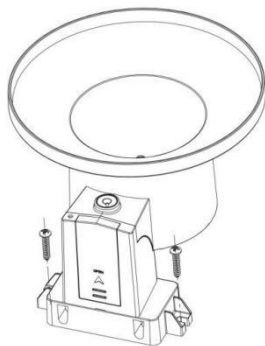

Note: Use the bubble level beside the rain sensor as a guide to verify that the sensor is leveled.

Best Practices for Wireless Communication

Wireless communication is susceptible to interference, distance, walls and metal barriers. We recommend the following best practices for trouble free wireless communication.

1. **Electro-Magnetic Interference (EMI).** Keep the console several feet away from computer monitors and TVs.
2. **Radio Frequency Interference (RFI).** If you have other 915 MHz devices and communication is intermittent, try turning off these other devices for troubleshooting purposes. You may need to relocate the transmitters or receivers to avoid

- intermittent communication.
3. **Line of Sight Rating.** This device is rated at 300 feet line of sight (no interference, barriers or walls) but typically you will get 100 feet maximum under most real-world installations, which include passing through barriers or walls.
 4. **Metal Barriers.** Radio frequency will not pass through metal barriers such as aluminum siding. If you have metal siding, align the remote and console through a window to get a clear line of sight.

3. Console Operation

Program mode

The screen is divided into 5 segments for selection. There are seven program modes: normal, setting mode, day rain history mode, month rain history mode, max/min mode, HI/LO alarm set mode and factory reset/clear memory.

All the modes can be exited at any time by pressing the HISTORY key, or waiting for a 15 second timeout to take effect.

Button Function

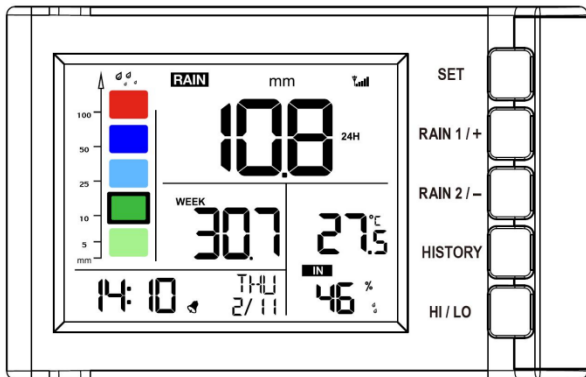

SET: enter the setting mode

RAIN 1 /+:display RATE,EVENT,1H,24H(normal mode) or + (programming mode)

RAIN 2 /-:display DAY, WEEK, MONTH, YEAR, TOTAL(normal mode) or- (programming mode)

HISTORY: display history records / return to normal mode

HI/LO: display the MAX, MIN value(normal mode) / Set Alarm (long press to enter setting alarm mode)

3.1 Normal Mode

3.1.1 In Normal Mode, press the “RAIN 1/+” button to alternate the display of:

- Display rain rate
- Display rain event
- Display rainfall total of 1h
- Display rainfall total of 24h

Note: Long press button “RAIN 1/+” over 5s will clear the current rainfall data displayed.

3.1.2 In Normal Mode, press the “RAIN 2/+” button to alternate the display of:

- Display rainfall of day
- Display rainfall of week
- Display rainfall of month
- Display rainfall of year
- Display rainfall of total

Note: Long press button “RAIN 2/+” over 5s will clear the current rainfall data displayed.

3.1.3 In normal mode, press the button “HISTORY” to enter Day Rain History Mode.

3.1.4 In normal mode, press the button “HI/LO” to enter HI/LO Alarm Set Mode.

3.2 SET Mode

In Normal Mode, long press the “SET” button for 2

seconds to enter Set Mode. The first setting will begin flashing. You can press the “SET” button again to skip any step, as defined below.

- a) 12/24 hour format
- b) Manual time setting (hours/minutes)
- c) Date format setting(D-M/ M-D)
- d) Date setting(year/month/day)
- e) Temperature unit setting(°C/°F)
- f) Rainfall unit setting(mm/in)

Note: In the setting mode, press” RAIN1/+” or ”RAIN2/-” buttons to change or scrolls the value. Hold the button for 2 seconds can change fast.

The setting mode will return to normal display while idle 15s or by pressing the button “HISTORY”.

3.3 Rain History Mode

In Normal Mode, short press the button “HISTORY” once to enter Day Rain History Mode, press “HISTORY” button twice will enter Month day history view mode;

Short press the button “RAIN1/+” or “RAIN2/+” to check the history rainfall data of the days or month displayed.

3.4 MIN/MAX Mode

In Normal Mode, press the button "HI/LO" to alternate the following max/min records with timestamp:

- a) Indoor temperature Max
- b) Indoor temperature Min
- c) Indoor humidity Max
- d) Indoor humidity Min

Note: Long press button "RAIN 2/+" over 5s will clear the current max/min records with timestamp displayed.

The setting mode will return to normal display while idle 15s

3.5 HI/LO Alarm Set Mode

In Normal Mode, long press the "HI/LO" button for 2 seconds to enter Alarm Set Mode. You can press the "HI/LO" button again to skip any step, as defined below.

- a) Time alert ON/OFF;
- b) Time alert value setting(hour/minute);
- c) Rainfall Rate HI alert ON/OFF;
- d) Rainfall Rate HI alert value setting;
- e) Rainfall Event HI alert ON/OFF;
- f) Rainfall Event HI alert value setting;
- g) Indoor temperature HI alert ON/OFF;

- h) Indoor temperature HI alert value setting;
- i) Indoor temperature LO alert ON/OFF;
- j) Indoor temperature LO alert value setting;
- k) Indoor humidity HI alert ON/OFF;
- l) Indoor humidity HI alert value setting;
- m) Indoor humidity LO alert ON/OFF;
- n) Indoor humidity LO alert value setting;

Note: In the alarm setting mode, press "RAIN1/+" or "RAIN2/-" buttons to change or scrolls the value. Hold the button for 2 seconds can change fast.

When the alarm value is reached, the corresponding alarm icon will flash and the buzzer will ring for 2min. The ringing can be stopped by pressing any button.

The setting mode will return to normal display while idle 15s or by pressing the button "HISTORY".

3.6 Factory Reset/Clear Memory

a. Press the button "SET" and "HI/LO" at the same time and power up the display will enter Factory Reset All previously set value will be reset to its default.

b. Press the button "RAIN1/+" and "RAIN2/+" for 5s, will register the transmitter signal for 3 minutes.

4. Function

a) Date

Calendar (Month/date,2017-2099 Default Year 2017)
12/24 hr format selected

Alarm clock

b) Indoor temperature and humidity

Every 60 second the unit will measure indoor temperature and humidity.

Indoor temperature and humidity MAX,MIN records with timestamp

Temperature/humidity high/low alert

c) Rain

Every 49 second the unit will receive wireless rain sensor.

Rain1 record view: RATE,EVENT,1H,24H.

Rain2 record view: DAY, WEEK, MONTH, YEAR, TOTAL

Rain1 (Rate, Event, 1h, 24h rain data) against graph display

Rain Rate/Event alert

d) Rainfall history (24 monthly rain history and the 730 days have rain rainfall records)

e) Wireless Signal Strength Indicator

During the synchronization, it will reduce one signal segment if it has not received the signal once from the transmitter. It will increase one signal segment if it has received the signal once.

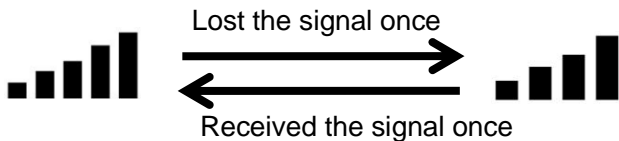

5. Maintenance

1. Clean the rain gauge once every 3 months. Rotate the funnel counter-clockwise and lift to expose the rain gauge mechanism, and clean with a damp cloth. Remove any dirt, debris and insects. If bug infestation is an issue, spray the array lightly with insecticide.

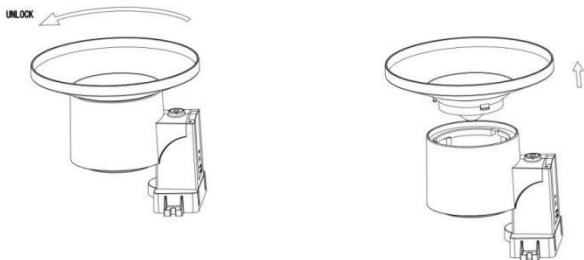
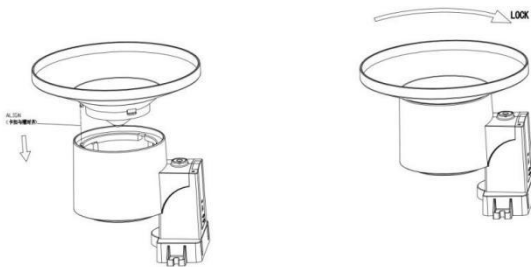

2. Replace batteries every 1-2 years. If left in too long, the batteries may leak due to environmental challenges. In harsh environments, inspect the batteries every 3 months.
3. When replacing the batteries, apply a corrosion preventive compound on the battery terminals, available at Amazon and most hardware stores.
4. In snowy environments, spray the top of the rain collector with anti-icing silicon spray to prevent snow build up.

6. Troubleshooting Guide

Problem	Solution
<p>Wireless remote (outdoor unit) not reporting in to console.</p> <p>There are dashes (--) on the display console.</p>	<p>Check the remote-transmitter LED for flashing.</p> <p>The outside sensor has an LED under the plastic, just above the battery compartment. The LED will flash every 48 seconds.</p> <p>If the LED is not flashing every 48 seconds, replace the batteries in the outside sensor.</p> <p>If the batteries were recently replaced, check the polarity. If the sensor is flashing every 48 seconds, proceed to the next step.</p> <p>There may be a temporary loss of</p>

Problem	Solution
	<p>communication due to reception loss related to interference or other location factors, or the batteries may have been changed in the remote and the console has not been reset.</p> <p>The solution may be as simple as powering down and up the console.</p> <ol style="list-style-type: none"> 1. Make sure you have fresh batteries in the display console. 2. With the sensor array and console 10 feet away from each other, remove the batteries from the display console and wait 10 seconds. Put the batteries back in. 3. Do not touch any buttons for several minutes. 4. The remote sensor search icon  will splash on the display. Wait several minutes for this icon to turn off. 5. If the search icon turns off and the outdoor temperature and humidity are still showing dashes (--), the remote sensor is defective. If the sensor properly syncs up, proceed to the next step "How to prevent intermittent wireless communication" <p>How to prevent intermittent wireless communication issues:</p> <ol style="list-style-type: none"> 1. Install a fresh set of batteries in the remote sensor array and console. For cold weather environments, install

Problem	Solution
	<p>lithium batteries.</p> <ol style="list-style-type: none"> 2. The maximum line of sight communication range is 300" but most users will get 100" or less due to environmental conditions. Move the sensor and remote closer together. 3. If the sensor assembly is too close (less than 5'), move the sensor assembly away from the display console. 4. Make sure the remote sensors are not transmitting through solid metal like aluminum siding (acts as an RF shield), or earth barrier (down a hill). 5. Move the display console around electrical noise generating devices, such as computers, TVs and other wireless transmitters or receivers. 6. Move the remote sensor to a higher location. Move the remote sensor to a closer location.
Temperature reads too high in the day time.	Make sure the console is placed in a shaded area on the north facing wall.
Display console contrast is weak	Replace console batteries with a fresh set of batteries.

7. Specifications

Outdoor data

Measuring interval: 49 sec

Transmission distance in open field: 100m(300 feet)

Frequency: 433/868 MHz (option)

Indoor data

Measuring interval: 61 sec

Rain fall measuring range: 0--6000mm

Indoor temperature range: -9.9°C--60°C

(14°F to + 140°F)

Accuracy: $\pm 1^{\circ}\text{F}/\pm 0.5^{\circ}\text{C}$.

Indoor humidity measure range: 10% to 99%.

Accuracy: $\pm 6\%$ RH (@25°C. , 30%RH to 80%RH)

Accuracy: $\pm 5\%$ RH (@25°C. , 1%RH to 29%RH;
80%RH to 99%RH)

Power consumption

Base Station: 3xAA Alkaline batteries (not included)

Outdoor sensor: 1xAA Alkaline batteries (not included)

Battery life: Minimum 12 months for base station

Minimum 12 months for outdoor sensor



Please help in the preservation of the environment
and return used batteries to an authorized depot.

8. Liability Disclaimer

Reading the “User manual” is highly recommended. The manufacturer and supplier cannot accept any responsibility for any incorrect readings and any consequences that occur should an inaccurate reading take place.

This product is designed for use in the home only as indication of weather conditions. This product is not to be used for medical purposes or for public safety information.

The specifications of this product may change without prior notice.

This product is not a toy. Keep out of the reach of children.

9. Warranty Information

We disclaim any responsibility for any technical error or printing error, or their consequences.

All trademarks and patents are recognized.

We provide a 1-year limited warranty on this product against manufacturing defects in materials and workmanship.

This limited warranty begins on the original date of purchase, is valid only on products purchased and only to the original purchaser of this product. To receive warranty service, the purchaser must contact us for problem determination and service

procedures.

This warranty covers only actual defects within the product itself, and does not cover the cost of installation or removal from a fixed installation, normal set-up or adjustments, claims based on misrepresentation by the seller or performance variations resulting from installation-related circumstances.